

# Heilongjiang Huida Technology Co., LTD

FILE NAME (FILE NAME)	DOCUMENT NO. (FILE NO.)	EDITION (REV.)	DATE (DATE)	PAGE
HUIDA 18S SMART BATTERY SPECIFICATIONS	HE102	V1.0	2024-8-26	

## Huida 18S smart battery specifications

Model number (Model)

**HE102**

ADDRESS: HUIDA TECHNOLOGY, NO.685, XU ROAD, QINGPU DISTRICT, SHANGHAI

PRODUCTION (PREPARED)	REVIEW (CHECKED)	APPROVAL (APPROVED)
-----------------------	------------------	------------------------

# catalogue

1. Overview .....	2
2. System block diagram .....	3
3. Cell parameters .....	4
4. Battery parameters and test methods .....	4
5. Standard test environment .....	6
6. Indicator language .....	6
7. Physical drawing, size and structure .....	8
8. Definition of the battery interface .....	9
9. Smart battery function menu .....	9
10. Warning matters and precautions when using the products .....	11
11. Change records .....	14

# 1. summary

HE102 smart battery is a large capacity, high rate, long life agricultural machinery battery, using three-way high voltage system, built-in 18S cell. The maximum charging voltage shall not exceed 78.3V, the charge and discharge port is the same, the power plug adopts a special connector. Maximum sustained current of up to 300A. The battery integrates high-precision voltage, current and temperature sampling. Independent development of BMS algorithm, including adaptive SOC and SOH algorithm, non-inductive equilibrium algorithm, power storage algorithm, etc., in the process of battery use to independently learn parameters and modify the model, so that the battery is always in the best working state and storage state, prolong the battery life.

## **Smart batteries have the following characteristics:**

- 1) Safe and reliable, stable operation
- 2) Large capacity, large ratio, long life
- 3) Self-developed BMS hardware and algorithm, autonomous and controllable
- 4) AFE voltage, current, temperature accuracy is high, charging over voltage, overcurrent, over temperature and other multiple protection
- 5) Adaptive SOX algorithm, SOOC and SOH estimation accuracy
- 6) Non-inductive equilibrium and long-term storage algorithm
- 7) Support CAN bus and Bluetooth communication mode, can query real-time information, upgrade firmware, export log, etc
- 8) Support pre-charging, boot short circuit protection
- 9) Support site detection, no power supply and load cannot be enabled
- 10) Operating power consumption is low, and the battery consumption is low
- 11) Static monomer power consumption difference is small
- 12) It has the function of undervoltage dormancy and has little power consumption after dormancy
- 13) Autonomous power algorithm to accurately evaluate the battery residual power
- 14) Balalize function according to the remaining power of the single cell
- 15) With the CAN external communication interface
- 16) Maximum continuous discharge current is 300 A
- 17) Battery cell directly output, no undervoltage protection and overvoltage protection, need to use a special charger charging. After use, it needs to be removed from the aircraft or the charger, otherwise the battery will be overreleased.

## 2. system chart

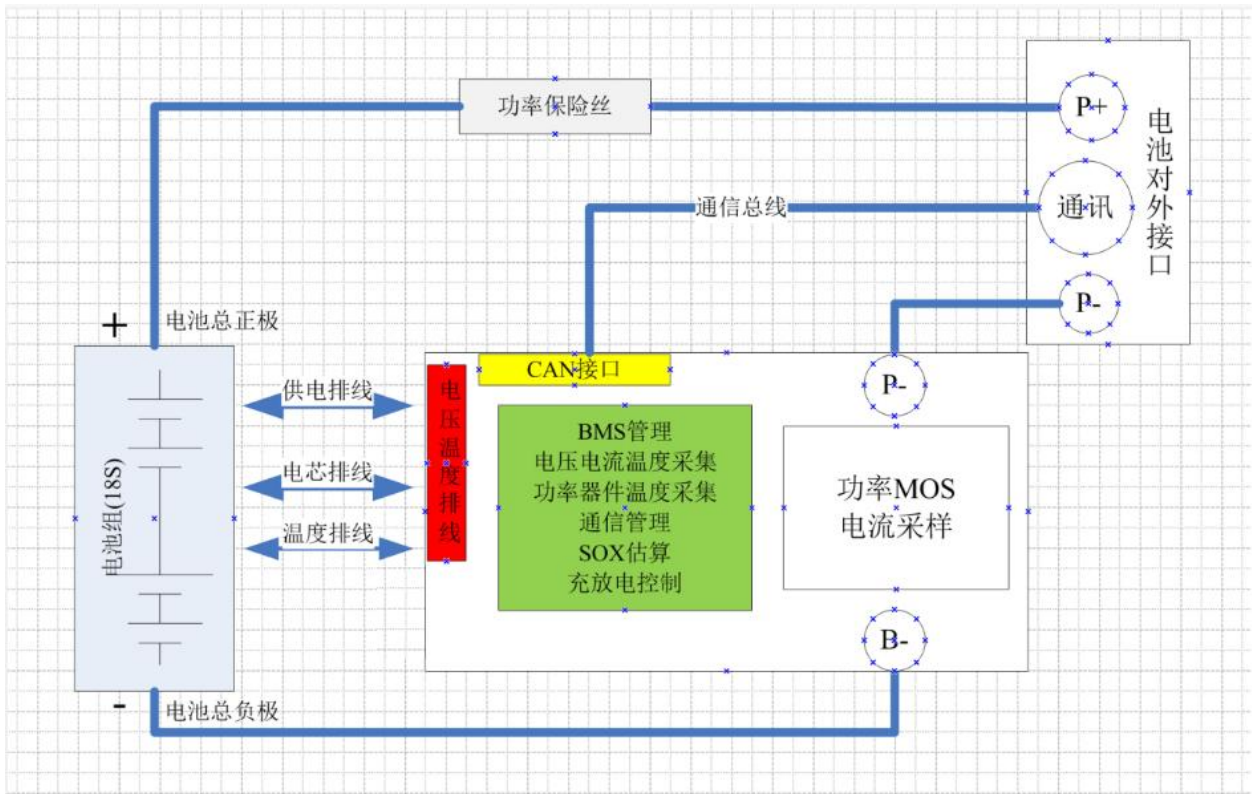

### 3. Cell parameters

#### 1) scope of application

This specification describes the product specifications for Huida Rechargeable Polymer Lithium-ion batteries.

#### 2) Cell model: FAP105105230-30Ah

#### 3) Cell specifications

order number	test item	parameter	
1	Charging cut-off voltage	4.35 V	
2	nominal voltage	3.75 V	
3	Discharge cut-off voltage	3.0V	
4	nominal capacity	30,000 mAh @ 0.5 C Discharge (discharge)	
5	Typical capacity	30500 mAh @ 0.5 C Discharge (discharge)	
6	Standard charging method	At the ambient temperature of $25 \pm 3^{\circ}\text{C}$ , the cell is charged to 4.35V in constant current with 1 Cmin, and then 4.35V in constant voltage until the charging current is less than or equal to 0.2 Cmin, the maximum charging time is not more than 1.5h, and the charging is stopped.	
7	Maximum charging current	5 C (charging temperature: $15^{\circ}\text{C} \sim 65^{\circ}\text{C}$ )	
8	Maximum discharge current	10C (discharge temperature: $15^{\circ}\text{C} \sim 65^{\circ}\text{C}$ )	
9	working temperature	Charging: $0^{\circ}\text{C} \sim 45^{\circ}\text{C}$ Discharge: $-20^{\circ}\text{C} \sim 55^{\circ}\text{C}$	
10	Battery weight	559 $\pm$ 5g (reference value)	
11	storage temperature	At- $20^{\circ}\text{C}$ to $45^{\circ}\text{C}$ Vacation was kept for 1 month At- $20^{\circ}\text{C}$ to $35^{\circ}\text{C}$ Vacation was kept for 6 months	The battery should be recycled once every 3 months
12	Shipping voltage	3.60~3.75V	
13	Initial internal resistance	$\leq 1\text{m}\Omega$	

### 4. Battery parameters and test methods

order	test item	parameter	
-------	-----------	-----------	--

number		
1	charging voltage	DC 78.3 V (charging with a smart charger, monitoring each cell voltage and charging window)
2	nominal voltage	67.5 V
3	nominal capacity	30Ah @0.5C Discharge (discharge) typical value
4	energy	2025 Wh
5	charging current	Standard charge: 1C (operating temperature range: 5~45°C)
6	Standard charging method	1C Charge to 78.3V until the current drops below 0.2C in CV mode
7	Fast charging method	Charge 4C to 78.3V until the current drops below 0.5C in CV mode
8	Maximum charging current	120A@5C
9	Maximum discharge current	300A@10C
10	Cell specifications	18S1P @(3.75V30Ah)
11	Charging temperature (battery cell)	Less than 0°C, cut-off for charging 0~10°C, 1C charging 10~60°C, 4C charging 60~65°C, 1C charging Greater than 65°C, cut-off for charging
12	Operating temperature (environment)	Charge: 0°C ~ 45°C Discharge: -10°C ~ 45°C
13	Store humidity	40-70RH%
14	storage temperature	10 ~ 30°C
15	Battery weight	Approx.: 14.5 KG
15	Battery size	Size of the shell included: 277 * 329.6 * 178.18 mm
16	Battery shipment voltage	64.8V~67.5 V
17	levels of protection	IP / 54 (reach IP / 56)
18	guarantee period	According to the contract
19	cycle life	1500 weeks 80% Test conditions: ambient temperature 25 ± 5 °C; 120A (4C) charge to

		78.3V,0.5CmA cut-off; discharge to 200A (full load) to 100A (no load); discharge capacity not less than 80% of the initial capacity.
--	--	--

## 5. Standard test environment

Unless specified, all tests in this Standard are performed under the following environmental conditions:

temperature:23°C±5°C

Humidity: 60 ± 20% RH

## 6. The indicator light language

Description: 30% 1,50% 2,70% 3,100% 4.

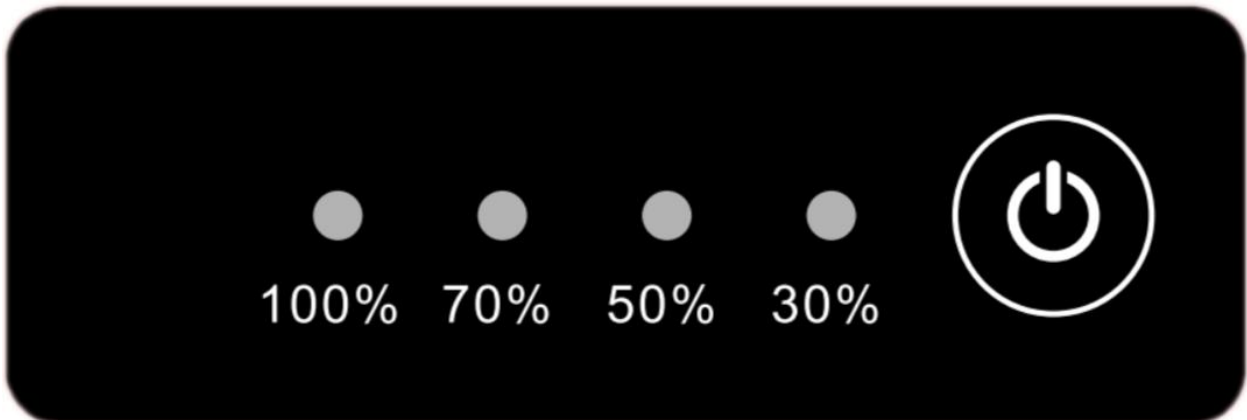

Power indicator light (green):

discharge condition:

pilot lamp	explain	remarks
1 The light flashing	soc<30%	
1 The lamp is often bright	30% soc, and soc <50%	
The 1-2 lights are often bright	50% soc, and soc <70%	
1-2-3 The lights are always on	70% soc, and soc <90%	
1-2-3-4 The lights are always on	soc≥90%	

charged state

pilot lamp	explain	remarks
1-2-3-4 lamp running water	soc<30%	
1 The lights are always on, 2-3-4 the light is running water	30% soc, and soc <50%	
1-2 lights are always on, and 3-4	50% soc, and soc <70%	

lights are running water		
1-2-3 lights are always on, 4 lights are running water	Soc > 70% until full out of charge state	

Status indicator light (red)

There are three definitions of state, namely constant bright, slow flash, and flash flash. The slow flash is 1Hz and the flash flash is 5Hz.

pilot lamp	explain	remarks
1 Light flash slowly	Boot short circuit	
1 Light flash	Pre-charge failure	
2 Light slow flash	The temperature of the cell is low	
2 Light flash	The temperature of the cell is high	
2 The light is often bright	The temperature of the cell is abnormal	
3 Light slow flash	The system (PCB, MOS, CON) temperature is low	
3 Lamp flash	The system (PCB, MOS, CON) is high	
3 The lamp is often bright	System (PCB, MOS, CON) temperature is abnormal	
4 Light slow flash	The cell is under pressure	
4 Light flash	The cell is overpressed	
4 The light is often bright	The cell is abnormal	
The 1-2 lights flash simultaneously	To the frequency	
The 1-2-3-4 the lights are always on at the same time	BMS hitch	

## 7. Physical drawings, dimensions and structure

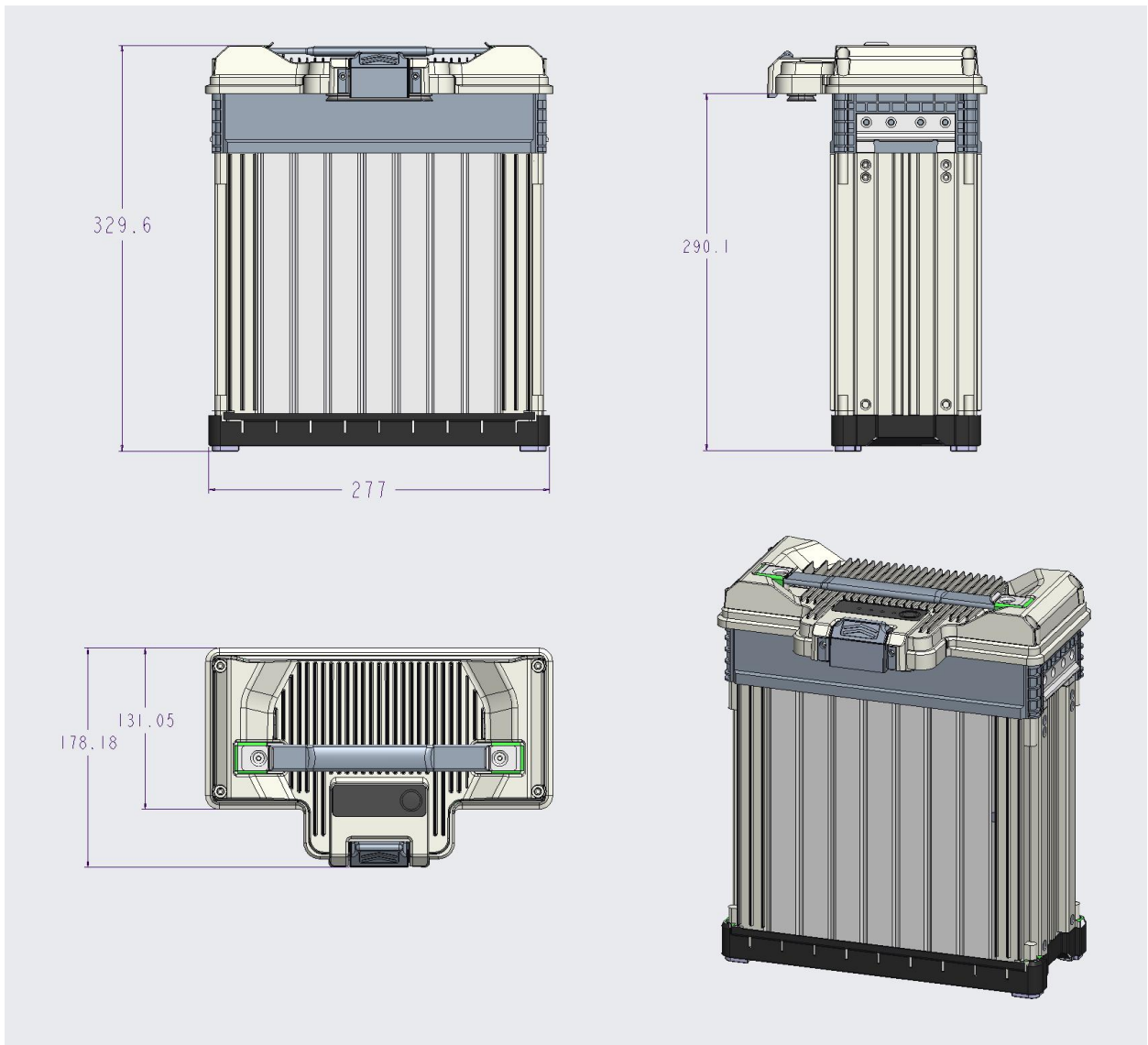

## 8. Definition of battery interface

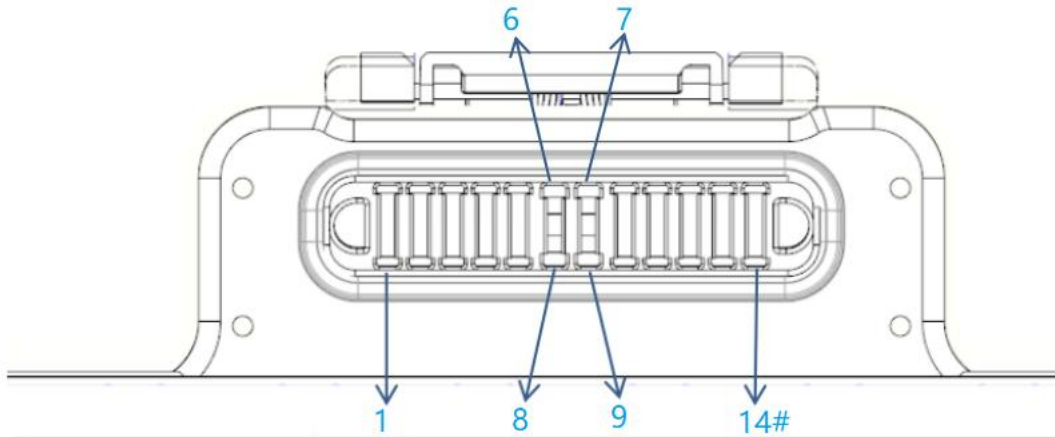

PIN#号	线色	名称	备注
1#/2#/3#/4#/5#	红色	电池P+	
6#		CAN_H	CAN正
7#		CAN_L	CAN负
8#/9#		预充检测	飞机端短接
10#/11#/12#/13#/14#	黑色	电池P-	

## 9. Smart battery menu

order number	function	description	remarks
1	Battery short circuit function	Battery input for short-circuit protection, 350A fuse	have
2	Battery overcharge function	Single-body voltage overcharge protection function	have
3	Battery charge overcurrent function	Battery segment charging and overcurrent function	have
4	Battery damage sign	The high temperature of the battery exceeds 85°C The single cell voltage is below 2.7 V	have
5	The flight was constantly charged	Discharge current is greater than the setting value, and the discharge is not protected	have

6	Over-release protection function	The battery discharge current is less than the set value, and the undervoltage protection starts normally.	have
6	Charging temperature protection	Charging is not allowed beyond the charging temperature range	have
7	Battery data records	Record the abnormal data during the battery usage	have

---

## 10. Warning items and precautions for product use

1. The user shall use the battery in the operating environment specified in this battery specification. If you need to use it outside of the specified environment, the user needs to Assess risks with Huida Technology.
2. The Company shall not be liable for accidents by using batteries outside the environment specified in this Specification.
3. The charging current of a single cell shall be less than the maximum charging current indicated in this specification.
4. The charging temperature of the cell must strictly comply with the temperature specified in this specification, and the charging must be prohibited at the above or below the specified temperature range.
5. When the battery voltage drops to 0V, do not charge the battery.
6. The discharge current shall not exceed the maximum discharge current specified in this specification. Excessive discharge current can lead to cell overheating and rapid capacity decay.
7. Due to the self-discharge of the battery, the long-term stored battery may be in an over-discharge state. Therefore, the batteries stored for a long time should be charged regularly to ensure that the voltage is above 54V to prevent the battery from overdischarging. Excessive discharge can lead to battery gas production and rapid capacity decay.
8. The battery shall be stored at the temperature and humidity conditions specified in this specification. The long-term stored battery voltage should be maintained between 57.6

---

V-64.8V.

9. Do not contact or scrape the battery with sharp objects.

10. Do not disassemble or open, squeeze, bend, or twist or cut the battery. These actions can cause a short circuit in the battery and cause a fire.

11. Do not change or modify the battery, and do not try to insert a foreign body into the battery.

12. Do not keep batteries in water or other liquids or exposed to fire, explosion or other dangerous environments.

13. Only use the battery in the system designed for it.

14. Using only the certified charging system for charging, the use of the uncertified charger will cause fire, explosion, liquid leakage and other dangers.

15. Do not short circuit the battery or allow the conductive metal to contact the positive and negative terminals of the battery.

16. Reasonable disposal of waste batteries or disposal in accordance with local standards.

17. Unreasonable use of batteries can cause fire and explosion.

18. Do not let the battery liquid into the skin or eyes when the battery leaks. If unfortunate, immediately rinse with plenty of water and sought

Doctor help.

19. Do not burn the battery or put it in a fire, which may cause an explosion.

20. No use of damaged batteries, batteries may be damaged in the process of transportation, such as any abnormal phenomenon found in the battery, such as battery packaging deformation, smell of electrolyte smell, electrolyte leakage, etc., the battery should be scrapped immediately and shall not be used.

---

21. There must be enough insulation layer between the battery lead line and the single battery to ensure that the battery pack is not short circuit.

22. Users are strictly prohibited to replace the battery cell.

---

## 11. chage record

<b>edition Version</b>	<b>date Date</b>	<b>author Editor</b>	<b>Change the content Changed Contents</b>
V1.0	2024-8-19		